

3. DISINFECTION SYSTEMS

Applications:

- Treated residual water, with turbidity or colour, disinfection for pathogens germs elimination, keeping the water quality inside the tank, according to the RD 1620/2007 norm.
- Application: the water can be reuse for different use like garden or golf course watering, sanitary reload, vehicle cleaning, etc.

Characteristics:

- Compact equipment for water reuse, in accordance with the R.D. 1620/2007 norm.
- HYPOCHLORITE DISINFECTION SYSTEM:
 - Possible assembly on the PEHD structure with accessories according to the configuration: protection filter, probe, probe-holder, flow adjustment valve, hydraulic power supply pipe, supply point valve.
 - Interconnected elements, structure assembly with other tertiary treatment elements or independently supplied.
 - Regulation system and chlorine control by means of:
 - Flow measures pumps proportionally to the free chlorine or redox average (it's possible to include a chlorine/redox/pH regulator)
 - Redox/free chlorine/pH display regulator.
 - Redox probe or potentiometric probe.
 - Equipment for pH control and measure. pH probe.
 - 220 V electric power supply equipment. IP 54 protection. Work temperature: 0 to 45°C.
- DISINFECTION SYSTEM BY ULTRAVIOLET RADIATION.
 - Possible assembly on a structure.
 - Radiation chamber in AISI 304 and AISI 316 stainless steel.
 - Manual or automatic cleaning.
 - Electronic control module with visual and acoustic alarm in case of light failure. Counter and light substitution alarm.
 - Optional: UV intensity sensor incorporation.

3.1.3. HYPOCHLORITE DISINFECTION STATION
REF: CVC-CE

Automatic chlorination equipment for WWTP effluent pathogen germs removal composed of:

- Vertical cylindrical contact – chloration chamber, brand Salher, made in GFRP with deflector
- Hypochlorite dosing station composed with :
 - 1 membrane dosing pump with electromagnetic activation, impulse regulator and inlet for level probe, flow 5 – 10 l/h, maximal pressure of 10 bar, power supply 220 V 50 – 60 Hz.
 - 1 cylindrical storage tank in polyethylene for product mix with a capacity of 120 liters.
 - 1 level probe for disconnection in case of lack of the product.
 - 1 accessories kit with dual ball check valve filter, injection pipe with dual ball check valve, 2 m suction pipe PVC-Glass, 4 m impulse pipe in polyethylene, ankle, screws and fuse.
 - Disinfectant agents storage tank.



There are 2 options:

Type 1: Disinfection chamber

Type 2: Disinfection chamber
Dosing pump
Sodium hypochlorite tank

REF : CVC-CE

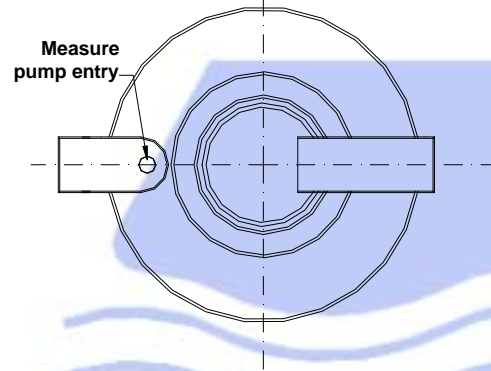
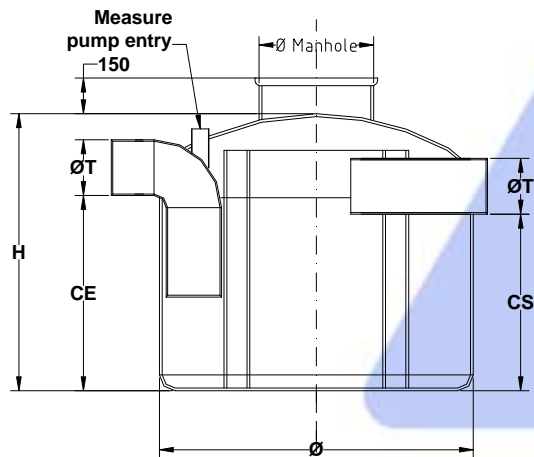

PE	CAPACITY (L)	\varnothing	HEIGHT	\varnothing MANHOLE	\varnothing PIPE
1 to 50	500	1.000	750	400	125
5 to 75	750	1.000	1.070	500	125
76 to 100	1.000	1.200	1.000	500	160
101 to 200	1.500	1.400	1.120	620	200
201 to 300	2.000	1.400	1.440	620	200
301 to 400	2.500	1.400	1.760	620	250
401 to 500	3.000	1.700	1.490	620	250
501 to 600	3.500	1.700	1.710	620	300
601 to 700	4.000	2.000	1.470	620	300
701 to 800	4.500	2.000	1.520	620	300
801 to 900	5.000	2.000	1.790	620	300
901 to 1.000	5.500	2.500	1.370	620	300

INNER SIZE IN MM